

Return Loss will be not less than -28db when Mounted on 27.5" Circular Back Plane

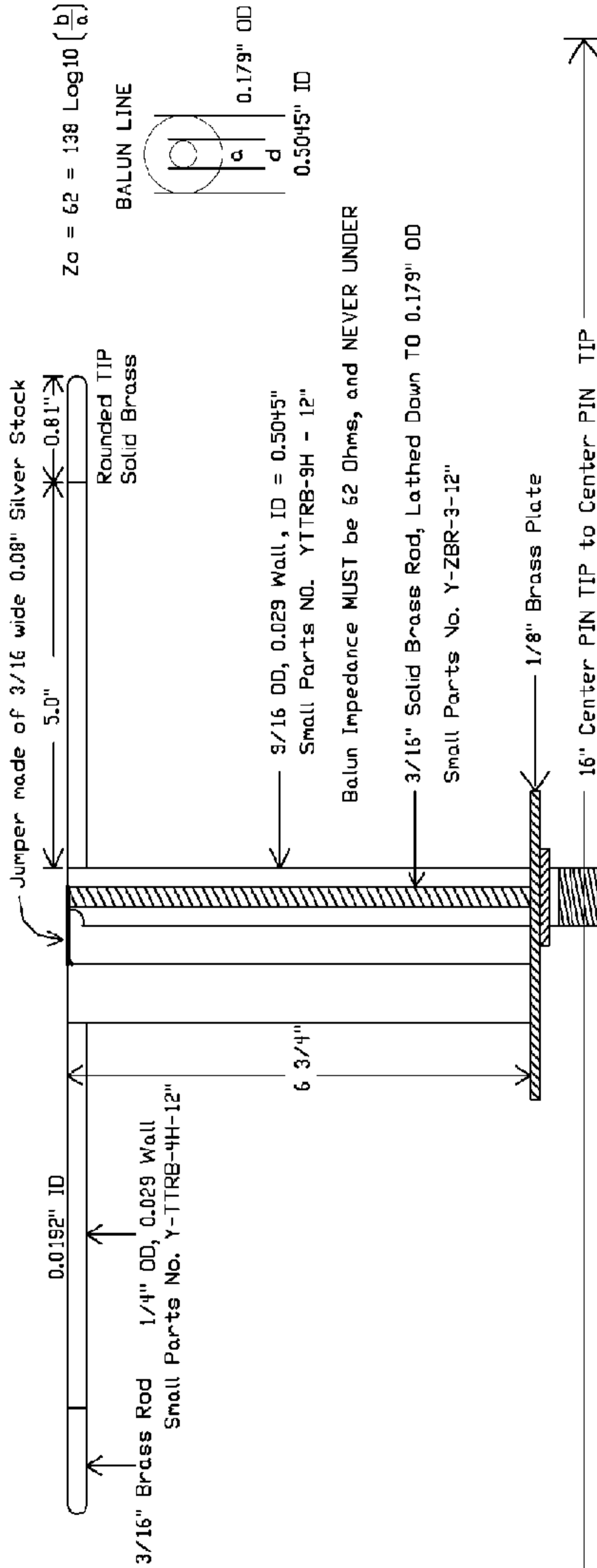

Length is NOT overly Critical but should be close and BOTH Lines EXACTLY the SAME

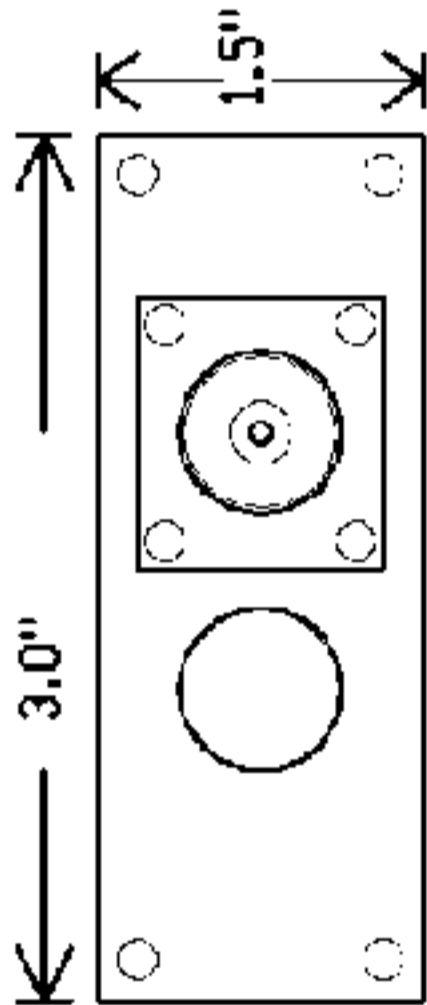

Belden 9292, 75 Ohm
VF 78% & 100% Shielding
Two Sections Required to connect to "N" Type "T" Connector at feed point from RF Relay

Co:	?
Title:	70cm Dipole Dish Feed
Board:	?
Author:	Revised By: VE1ALQ
Date:	April 1993
Revision:	A
Size:	A
Sheet	1 of 1

VE4MA 1296 MHz CIRCULAR POLARIZATION FEEDHORN

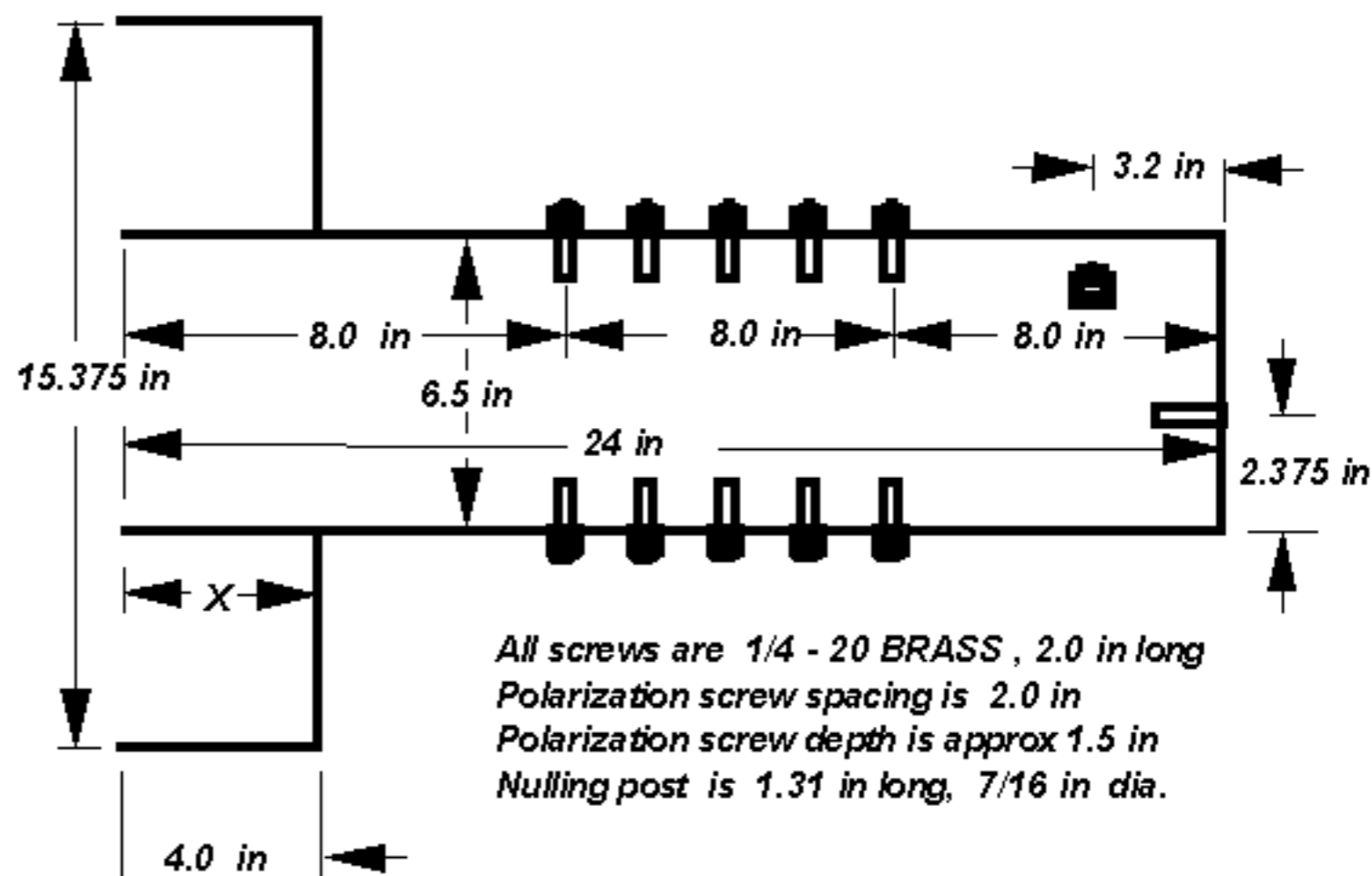
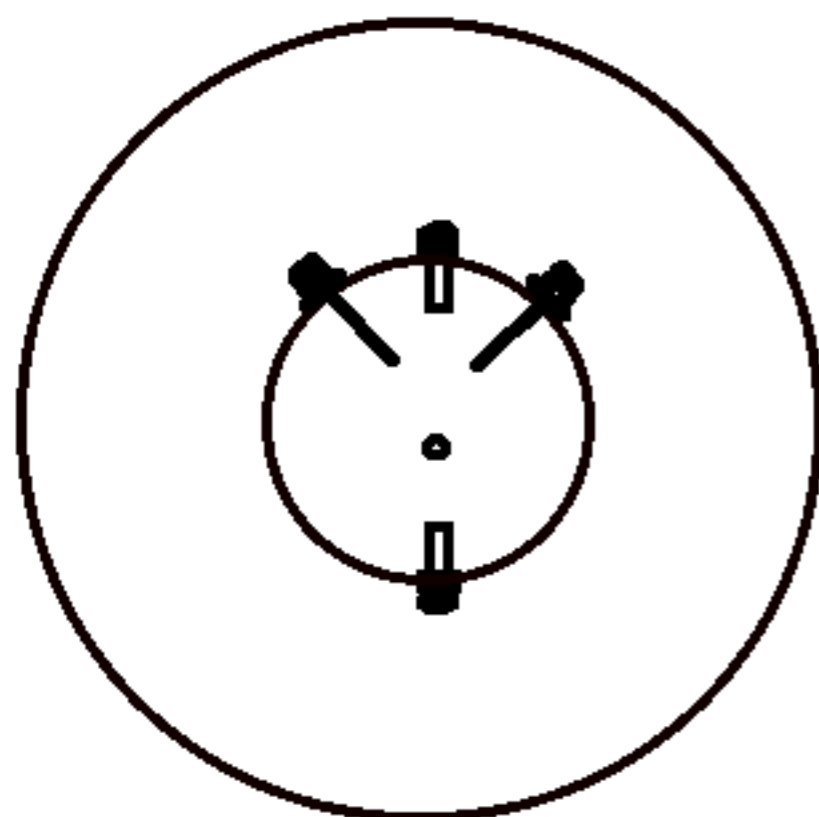

All screws are 1/4 - 20 BRASS , 2.0 in long
 Polarization screw spacing is 2.0 in
 Polarization screw depth is approx 1.5 in
 Nulling post is 1.31 in long, 7/16 in dia.

Distance X can be varied for different f/D ratios
 X is 4.0 in for f/ D of 0.4
 Polarizer screws should be optimized after X is set
 Drawing Not To Scale

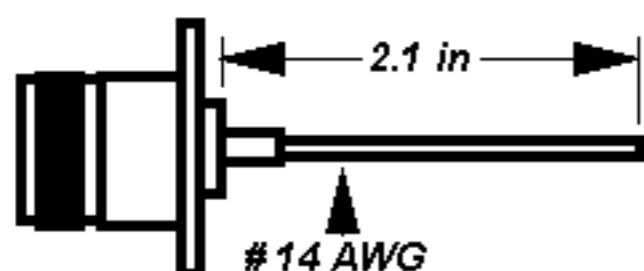

UG 58A/U

VE4MA 96 02 27

Please Note that These Scalar Ring Dimensions are **ONLY** for a 6.5 in Dia. (W2IMU) Main Feed

VE4MA 2304 MHz CIRCULAR POLARIZATION FEEDHORN

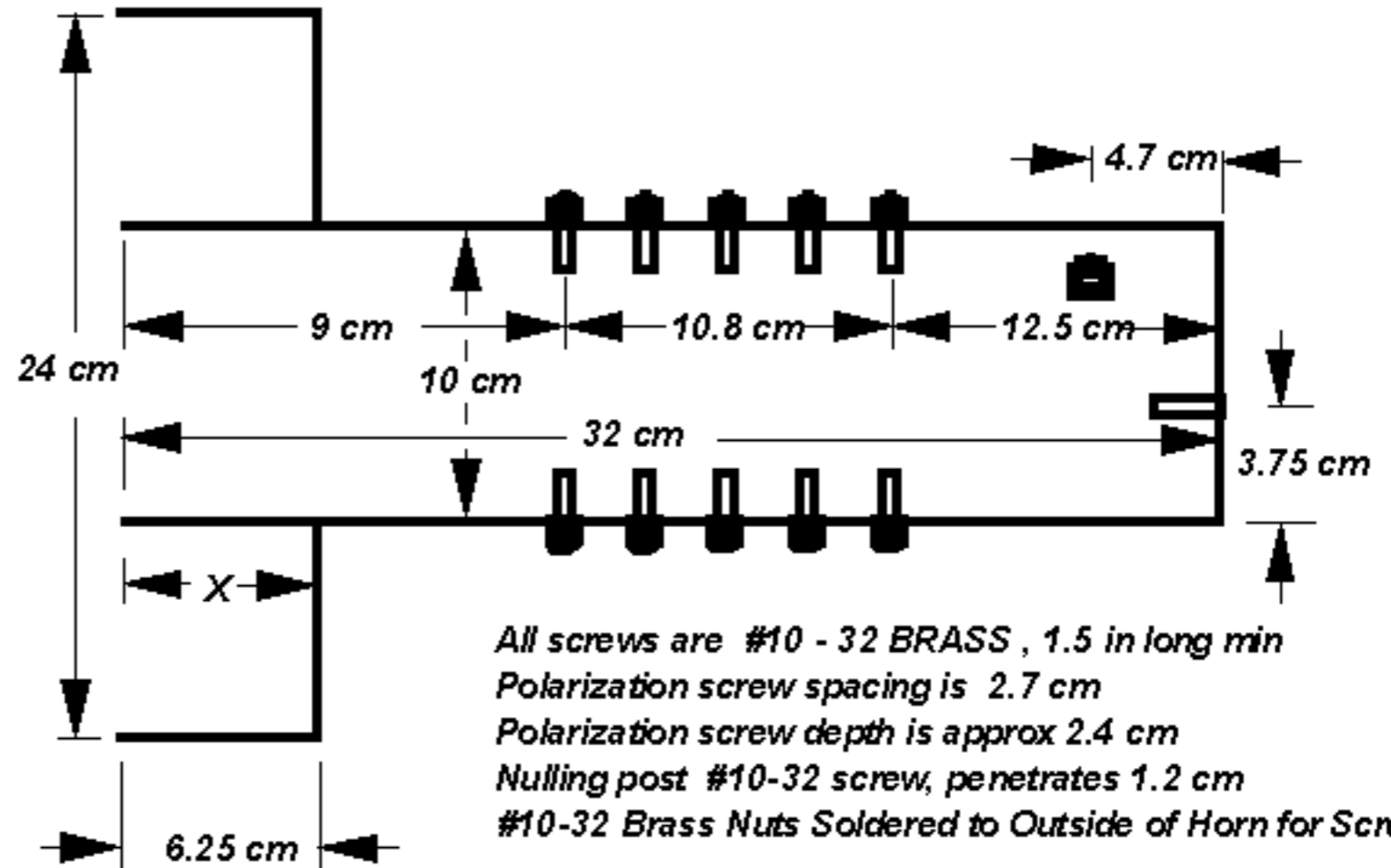
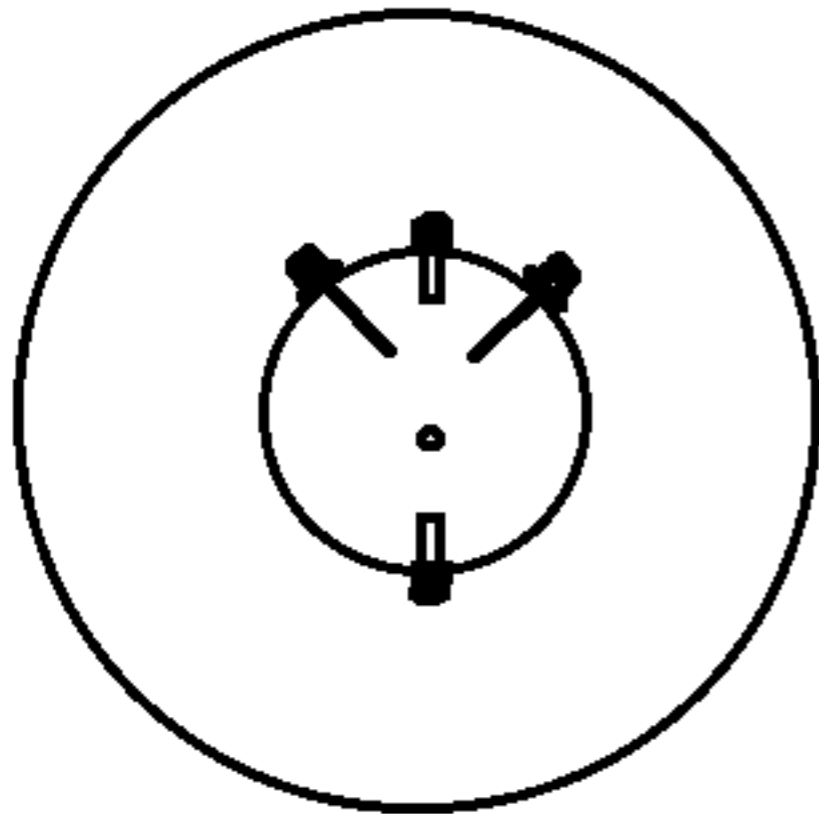

All screws are #10 - 32 BRASS , 1.5 in long min
 Polarization screw spacing is 2.7 cm
 Polarization screw depth is approx 2.4 cm
 Nulling post #10-32 screw, penetrates 1.2 cm
 #10-32 Brass Nuts Soldered to Outside of Horn for Screws

Distance X can be varied for different f/D ratios
 X is 6.25 cm for f/D of 0.4
 Polarizer screws should be optimized after X is set
 Drawing Not To Scale

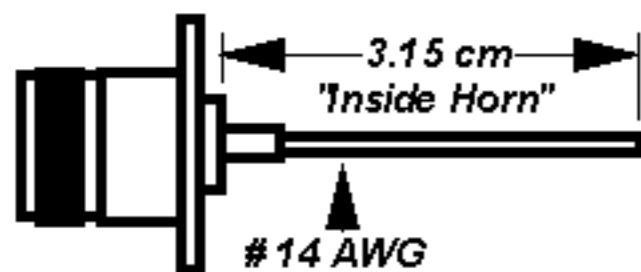

UG 58A/U

VE4MA 97 01 20

W2IMU 5760 MHz LINEAR POLARIZATION FEEDHORN

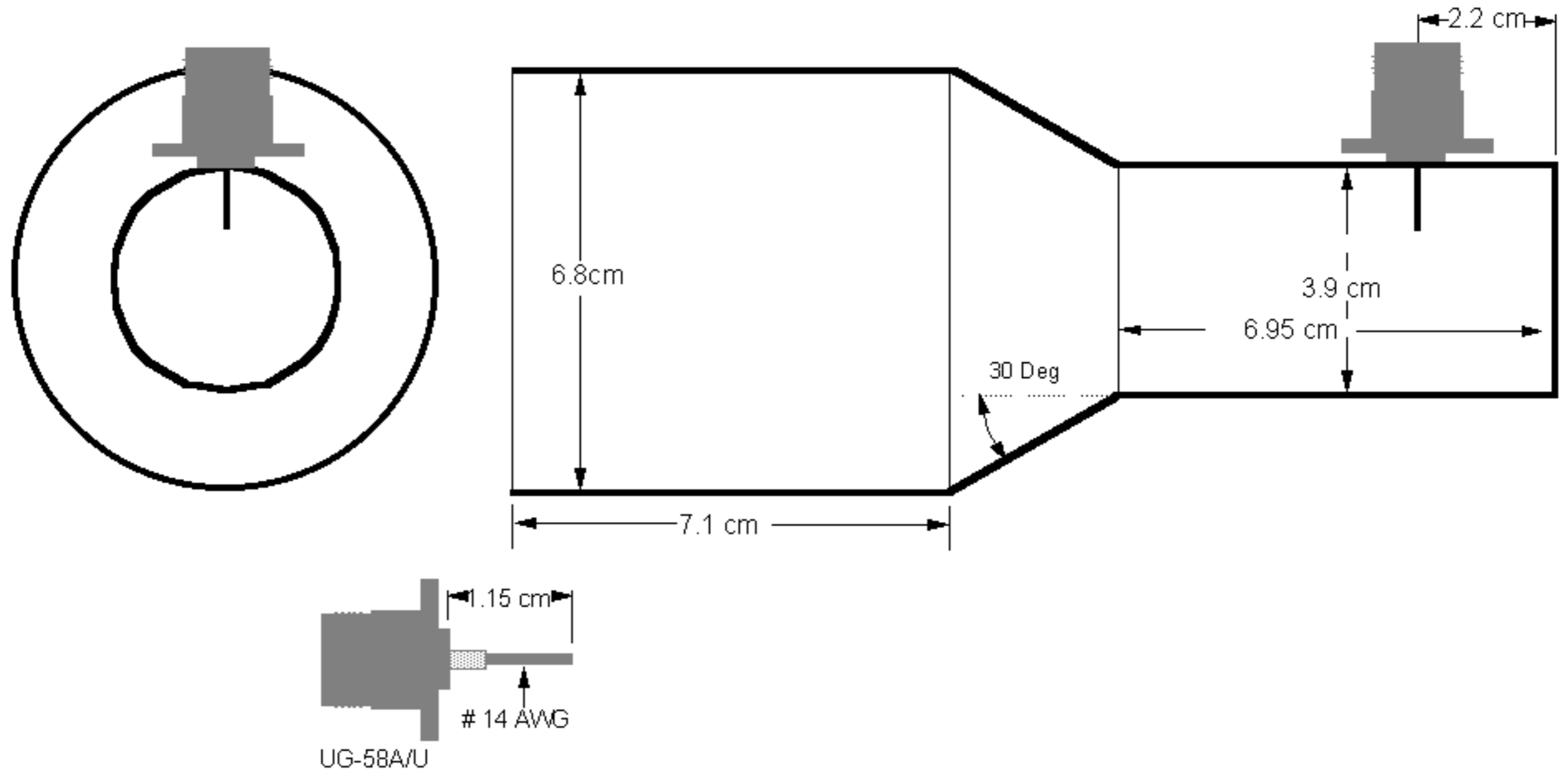

Main waveguide is 1.5 inch Copper Water Pipe

Hole drilled for connector is 3/8 in (0.953 cm).

Connector is supported on horn surface using 2 #4-40 screws, then soldered. Do not allow screws to penetrate into main WG.

Fill area under connector with Epoxy for mechanical strength

VE4MA 5760 MHz LINEAR POLARIZATION FEEDHORN

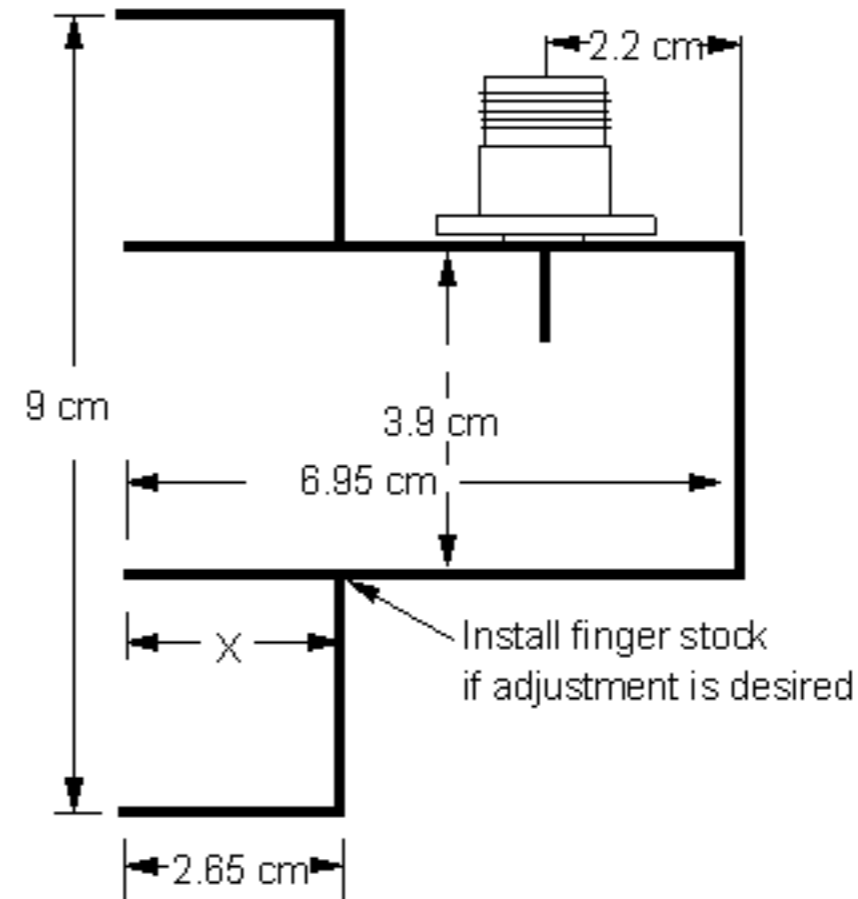
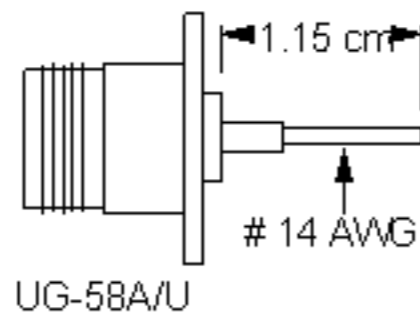
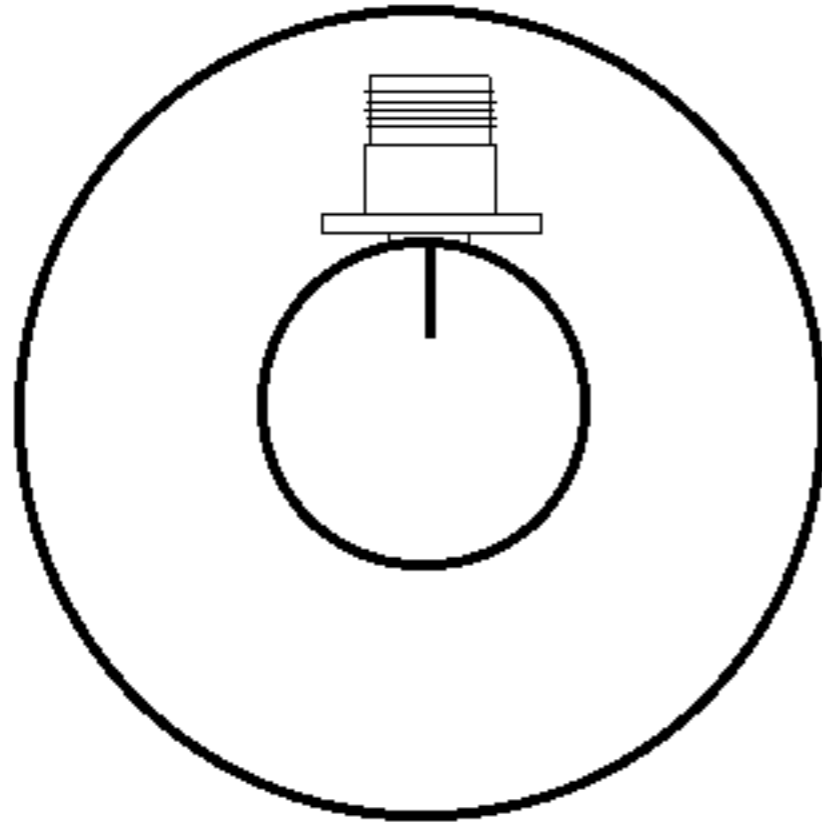

Distance X (cm) can be varied for different f/D ratios

f/D	0.5	0.45	0.40	0.35	0.30	0.25
LoNoise	2.13	2.27	2.65	2.84	3.1	3.2
MaxGain	2.52	2.65	2.9	3.1	3.3	N/A

Hole drilled for connector is 3/8 in (0.953 cm).

Connector is supported on horn surface using 2 #4-40 screws, then soldered. Do not allow screws to penetrate into main WG.

Fill area under connector with Epoxy for mechanical strength

Main waveguide is 1.5 inch Copper Water Pipe

VSWR measured 1.12: 1 (25 dB return loss) With Ring

VSWR measured 1.08: 1 (29 dB Return Loss) No Ring

5760 MHZ LINEAR POLARIZATION FEEDHORN WITH WR-137 FLANGE

3 E S Y 07

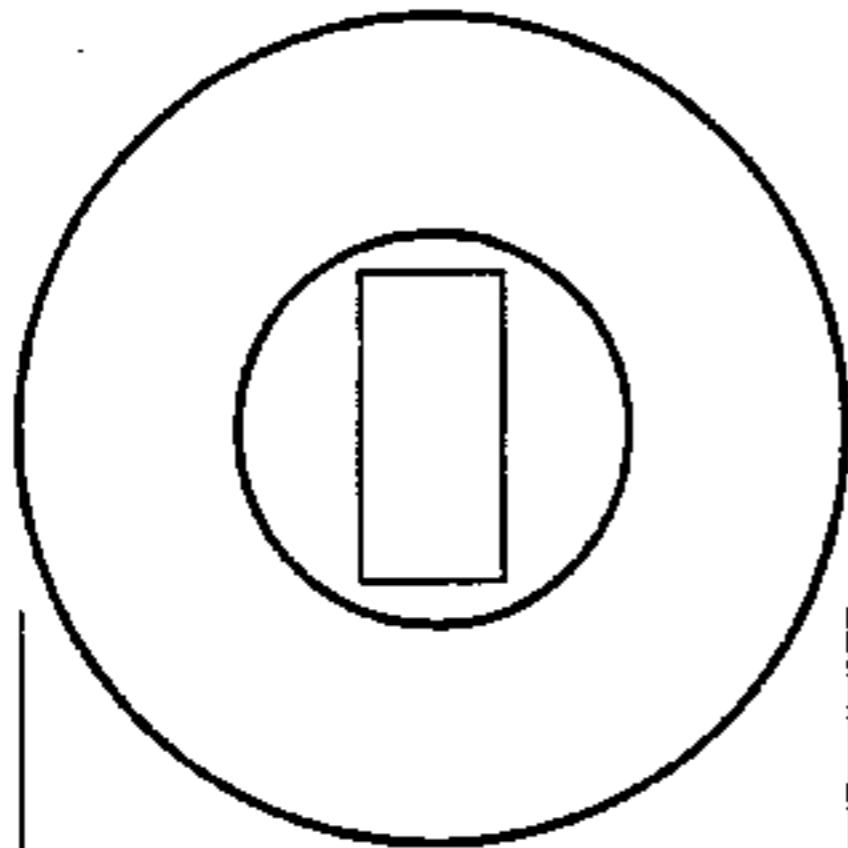
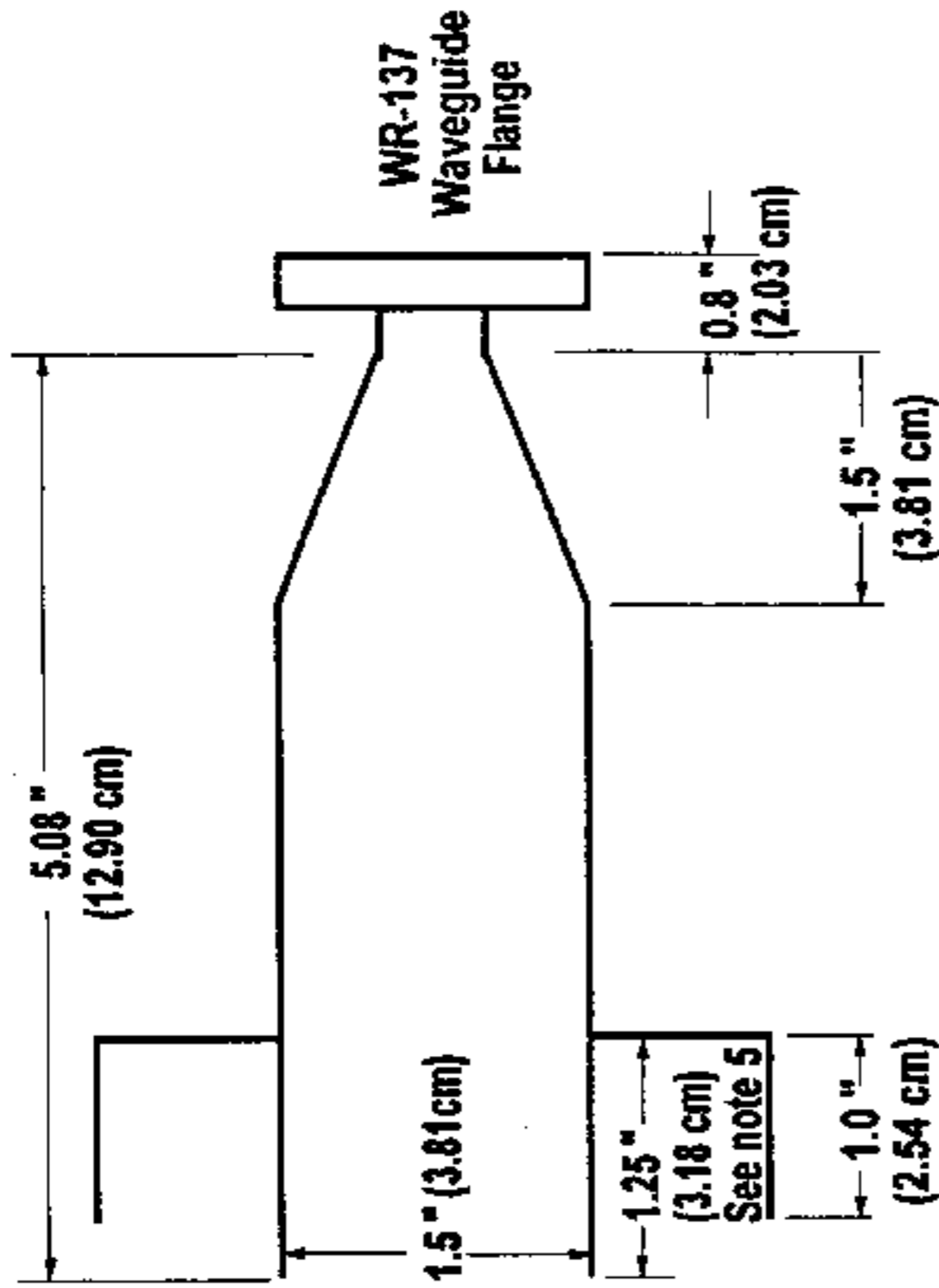

NOTES

1. Modified original VE4MA scalar feedhorn of date 95 02 28 for use with WR-137 flange. The end of the 1.5" copper pipe was formed to fit a short length of WR-137 waveguide and soldered.
2. Return Loss measured at 26 dB
3. Copper pipe length should be optimum but can be trimmed for best return loss.
4. Scalar ring is bottom section of a 1 lb. coffee can 1.0" high. Hole in end of can should be cut slightly smaller in diameter to be a tight fit around 1.5" pipe.
5. For my f/d of 0.4, I place the opening of the circular waveguide 0.25" in front of scalar ring. Probably still not optimum. Should be made variable. Reference original VE4MA drawing for suggestions for use with other f/d ratios.
6. I don't believe taper of 1.5" pipe is that critical as long as length of main waveguide can be trimmed for best return loss.

**DRAWING
NOT TO SCALE**

07-23-95

5760 MHZ WR-137 FEEDHORN

Engineering Sketch
by Al Ward WB5LUA

VE4MA 3456 MHz CIRCULAR POLARIZATION FEEDHORN

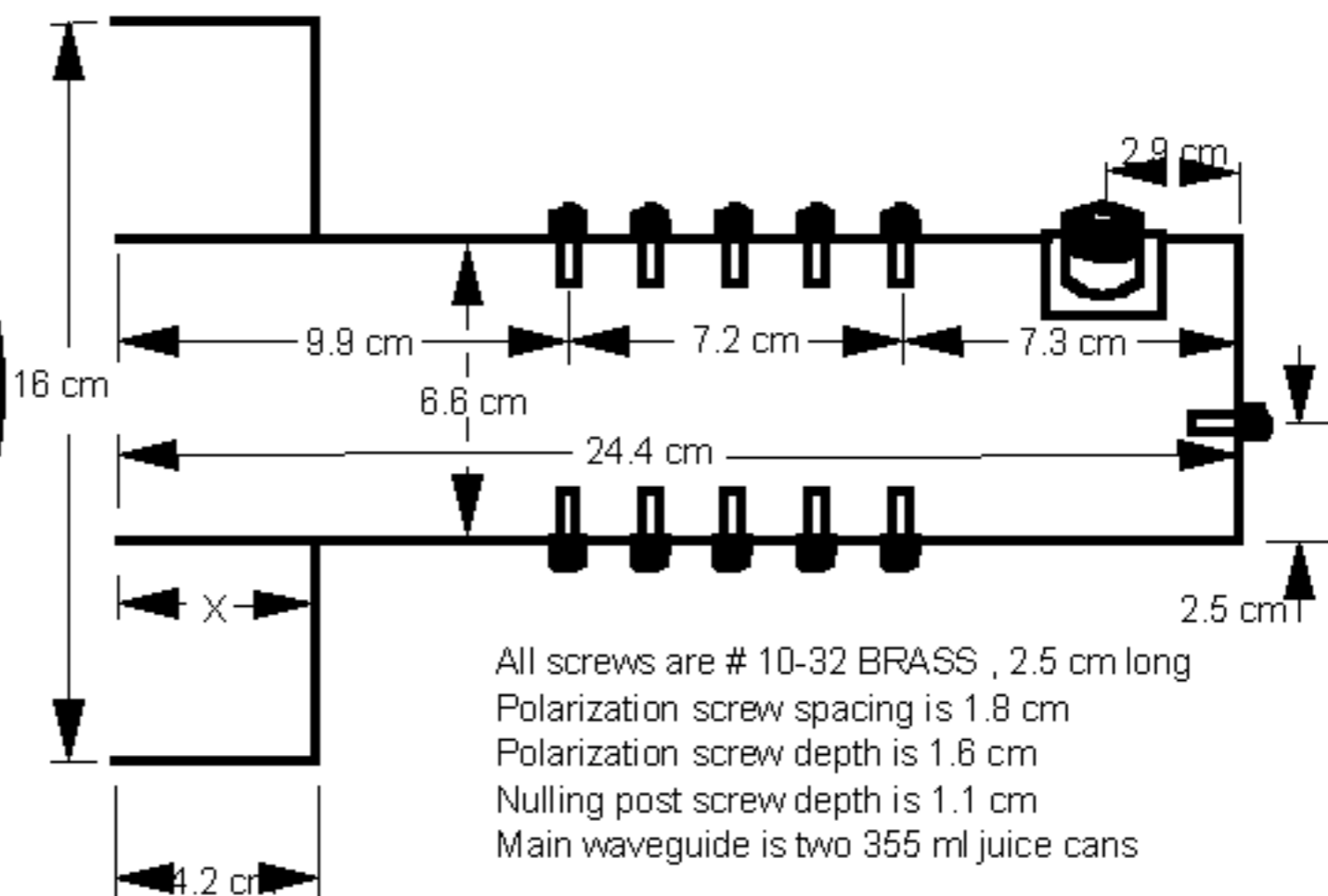
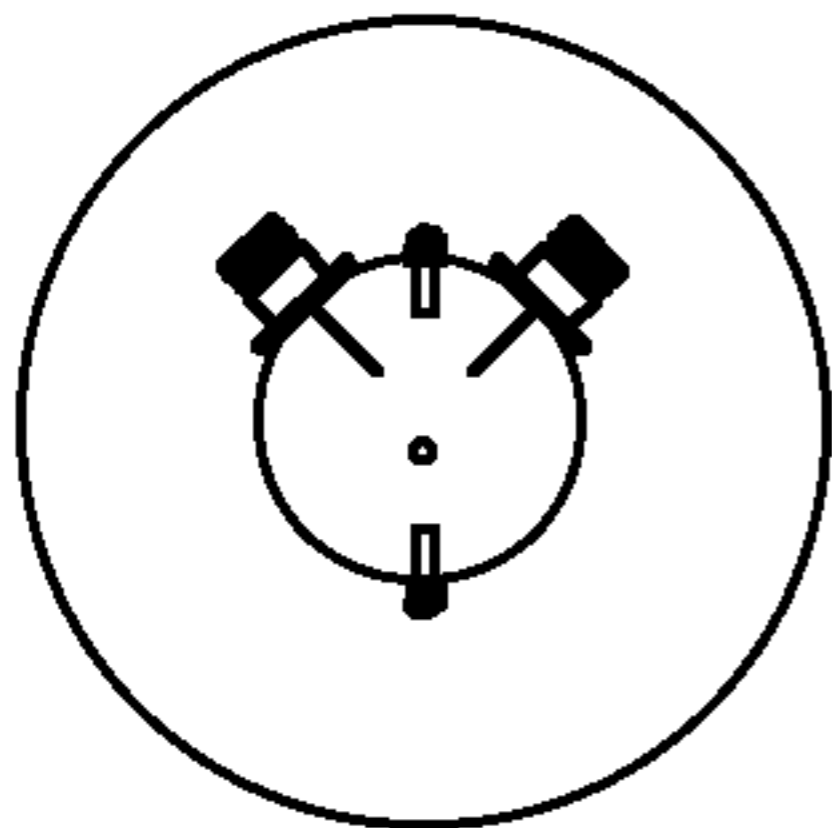

All screws are # 10-32 BRASS , 2.5 cm long
 Polarization screw spacing is 1.8 cm
 Polarization screw depth is 1.6 cm
 Nulling post screw depth is 1.1 cm
 Main waveguide is two 355 ml juice cans

VSWR measured 1.15 : 1 (23 dB return loss)
 Isolation between ports 23 dB
 Polarization axial ratio 1.5 dB

Distance X can be varied for different f/D ratios
 X is 4.2 cm for f/D of 0.4
 Polarizer screws should be optimized after X is set

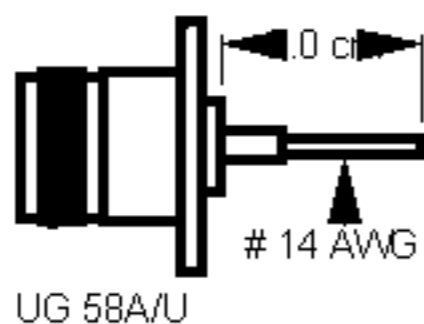

VE4MA 10 GHz COPPER WATER PIPE FEEDHORN

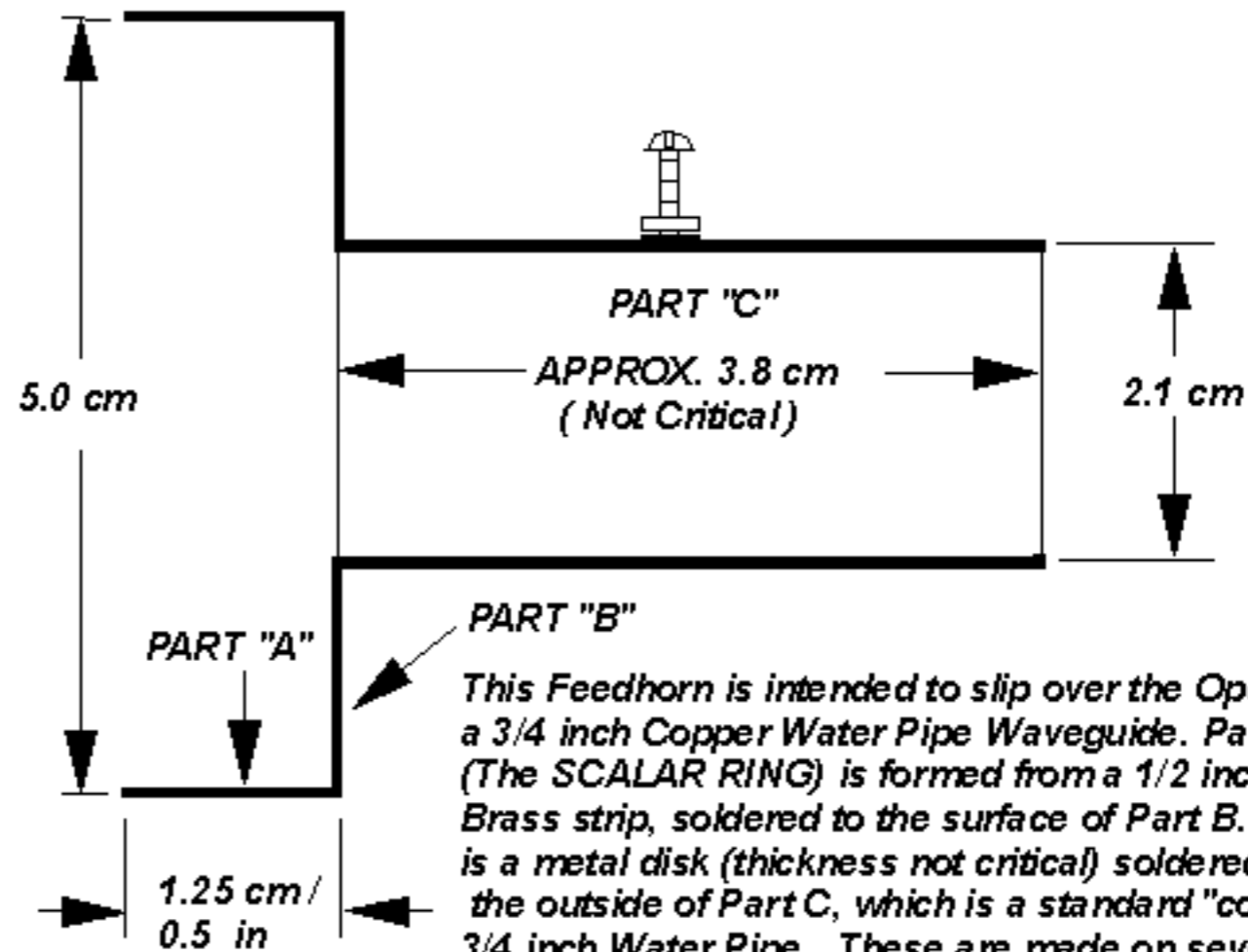
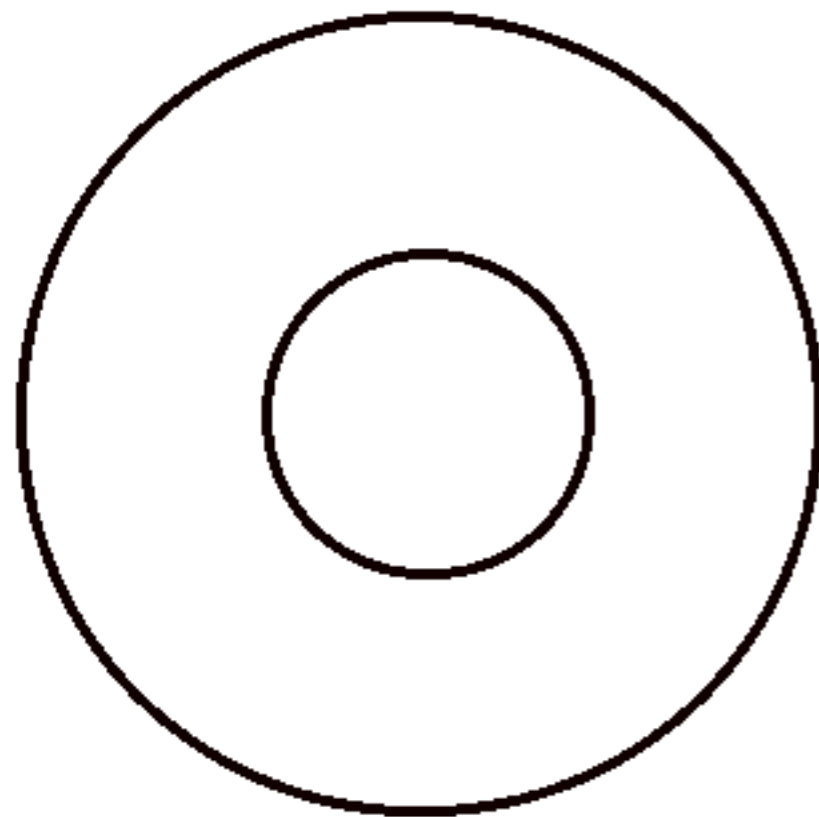

PART "B"
This Feedhorn is intended to slip over the Open End of a 3/4 inch Copper Water Pipe Waveguide. Part A (The SCALAR RING) is formed from a 1/2 inch wide Brass strip, soldered to the surface of Part B. Part B is a metal disk (thickness not critical) soldered to the outside of Part C, which is a standard "coupling" for 3/4 inch Water Pipe. These are made on several forms, but try to obtain one with a centre dimple (not ring). The dimple can be drilled out and tapped to receive the set screw. The set screw is #4-40 or Equivalent.

The Distance along the Feed Pipe can be varied for different f/D ratios. The Open Face of the Scalar Ring is flush with End of the Feed Pipe for an f / D of 0.4

Drawing Not To Scale

VE4MA 97 08 15

Please Note that These Scalar Ring Dimensions are **ONLY** for a " 3/4 INCH " WATER PIPE

VE4MA 24 GHz FEEDHORN

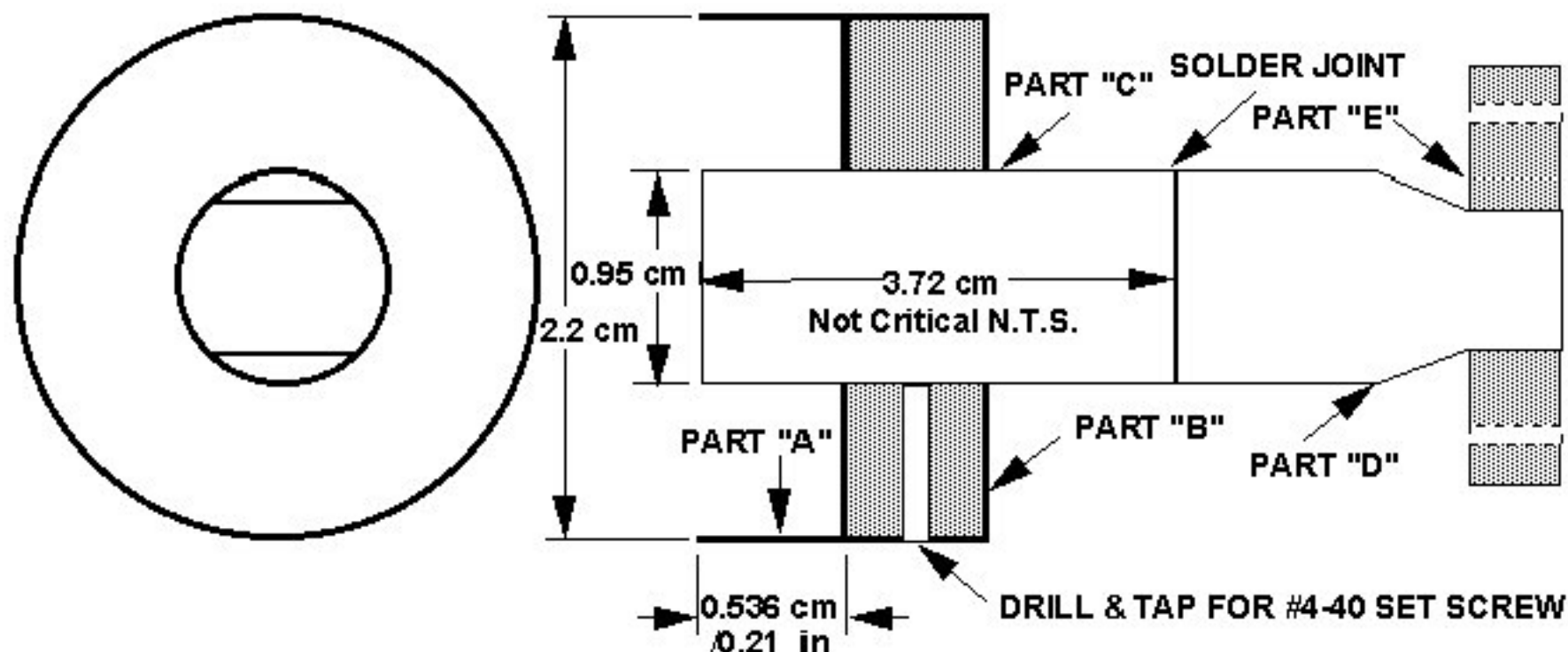

Part A ,the SCALAR RING is formed from a piece from a "3/4" inch copper water pipe coupling 0.536 cm wide.

Part B is a brass disk (thickness not critical) soldered to one end of Part A. Part B is intended to fit closely over Part C, but is able to slip back and forth to adjust for different f/Ds. The Open Face of the Scalar Ring is flush with end of Part C for an f / D of 0.4 . Part B is drilled and tapped to receive a #4-40 or equivalent, which secures it against the outside of Part C.

Part C is a section of copper or brass "tubing" 11.1 mm outside and 9.5 mm inside.

Part D is a soft copper "3/8" plumbing coupler which is the correct diameter to be carefully soldered to the end (butt jointed) of Part C. The other end of the coupler is formed "squeezed & shaped" to fit inside a WR-42 Waveguide flange and is soldered.

VE4MA 99 05 21

Drawing Not To Scale